

**COLLECTION OF THE CTL DECISIONS
DECISION SHEET**

Standard(s): IEC 60950:1999, 3 rd ed	Sub clause(s): 2.10.5.2	Sheet No.: 392
Subject: Test of non-separable thin sheet material	Key words: - Thin sheet material	Decision taken at the 39 th meeting 2002
<p>Question: How is non-separable thin sheet insulation in wound components tested?</p> <p>Rationale: There are non-separable thin sheet foils on the market and used in wound components, which cannot be tested according to the requirements and test-method in the existing standard. A proposal was made to TC74-WG6 how this matter can be handled. The proposal is attached.</p> <p>Decision: <u>Use of non-separable thin sheet insulation in wound components</u> The following proposal shall be used until the new edition is published.</p> <p><u>1. Introduction</u> This document presents two alternative versions of the test procedure given in IEC 61558-1 for checking the mechanical durability of thin sheet materials. Test method X adapts the published procedure to the conventions and practices used in IEC 60950. In Method X, the metal foil is secured to the sample prior to the test. Test method Y is the slightly different procedure observed on a video presentation, whereby the metal foil is only added to the test assembly after the sample has been stressed by rotating it in the test fixture. Test method Y appears to be the more practical method, and is evidently how the test is carried out in at least one test laboratory. The two methods should give the same results.</p> <p><u>2. Proposal</u> <i>Change the title of 2.10.5.2 to the following:</i> 2.10.5.2 Separable thin-sheet material <i>Modify the first paragraph of 2.10.5.2 as follows:</i> Insulation in separable thin sheet materials, and in two layers of non-separable thin sheet materials, is permitted, <i>Add a new sub-clause 2.10.5.X <u>or</u> 2.10.5.Y.</i> </p>		

Test Method X

2.10.5.X Non-separable thin sheet material

Insulation in three or more layers of non-separable thin-sheet materials is permitted for use within the equipment ENCLOSURE, and shall not be subject to handling or abrasion during servicing. It shall have adequate mechanical strength.

NOTE - The purpose of the tests in 2.10.5.X is to reveal defects that are hidden in inner layers of insulation, so there is no test for insulation in two layers. For insulation in two layers of non-separable thin-sheet materials, see 2.10.5.2

There is no requirement regarding distances through insulation, nor for all layers of insulation to be of the same material.

Compliance is checked by inspection and by the following test:

Three test samples of thin sheet material are used, each approximately 70 mm wide.

One sample is fixed to the mandrel of the test fixture as shown in figure 5X.

A sheet of aluminium or copper foil, 0,035 mm \pm 0,005 mm thick, approximately 30 mm wide and at least 100 mm long, is fixed to the surface of the sample. The foil is positioned so that its edges are approximately 20 mm from the edges of the sample (see figure 5Xd) and so that when the mandrel is in its final position, the foil overlaps the free end of the sample by at least 10 mm (see figure 5Xc). The foil is tightened by a pull of approximately 1 N, using an appropriate clamping device.

A pull of 150 N is applied to the free end of the sample, using an appropriate clamping device. The mandrel is twice rotated forwards and backwards by 230°, and then forwards to the final position. While the mandrel is in its final position, and within the 60 s following the final positioning, an electric strength test is applied between the mandrel and the metal foil in accordance with 5.2.2, using a test voltage of 1,5 times the value specified in table 5B.

The test is repeated with the other two samples

If a sample breaks at the clamping device during rotation, the test is repeated on a fresh sample. If one or more samples breaks at any other place, the test has failed.

.....

Add new Figure 5X (adapted from Figure 6 of IEC 61558-1)

Figure 5Xa is as figure 6a of IEC 61558-1, modified as follows:

Replace "3 x R = 0,5 \pm 0,02" by "R = 0,5 \pm 0,02 (typ)"

Replace "Material: steel nickel plated or brass" by "Material: metal"

Figure 5Xd is the same as figure 6c of IEC 61558-1

Test Method Y

2.10.5.Y Non-separable thin sheet material

Insulation in three or more layers of non-separable thin-sheet materials is permitted for use within the equipment ENCLOSURE, and shall not be subject to handling or abrasion during servicing. It shall have adequate mechanical strength.

NOTE - The purpose of the tests in 2.10.5.y is to reveal defects that are hidden in inner layers of insulation, so there is no test for insulation in two layers. For insulation in two layers of non-separable thin-sheet materials, see 2.10.5.2

There is no requirement regarding distances through insulation, nor for all layers of insulation to be of the same material.

Compliance is checked by inspection and by the following test:

Three test samples of thin sheet material are used, each approximately 70 mm wide.

One sample is fixed to the mandrel of the test fixture as shown in figure 5Y.

A pull of 150 N is applied to the free end of the sample, using an appropriate clamping device. The mandrel is twice rotated forwards and backwards by 230°, and then forwards to the final position.

A sheet of aluminium or copper foil, 0,035 mm ± 0,005 mm thick, approximately 30 mm wide and at least 200 mm long, is placed across is the surface of the sample, hanging down on each side of the mandrel. The foil is tightened by a pull of approximately 1 N at each end, using appropriate clamping devices.. The foil is positioned so that its edges are approximately 20 mm from the edges of the sample (see figure 5Yd).

While the mandrel is in its final position, and within the 60 s following the final positioning, an electric strength test is applied between the mandrel and the metal foil in accordance with 5.2.2, using a test voltage of 1,5 times the value specified in table 5B.

The test is repeated with the other two samples

If a sample breaks at the clamping device during rotation, the test is repeated on a fresh sample. If one or more samples breaks at any other place, the test has failed.

Add new Figure 5Y (adapted from Figure 6 of IEC 61558-1)

Figure 5Ya is as figure 6a of IEC 61558-1, modified as follows:

Replace "3xR = 0,5 ± 0,02" by "R = 0,5 ± 0,02 (typ)"

Replace "Material : steel nickel plated or brass" by "Material: metal"

Figure 5Yd is the same as figure 6c of IEC 61558-1

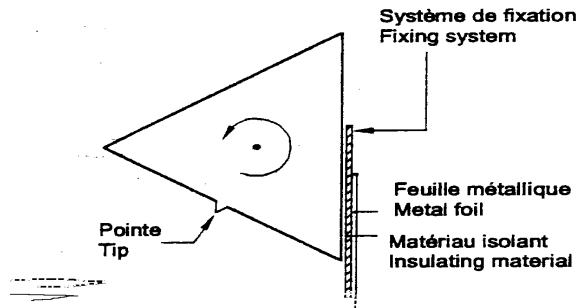

Figure 5Xb - Initial position of mandrel

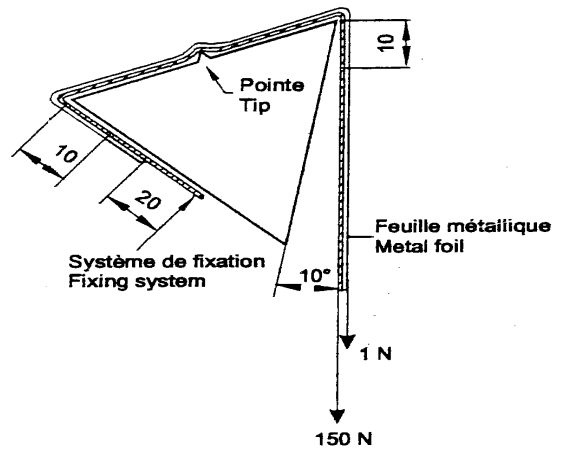

Figure 5Xc - Final position of mandrel

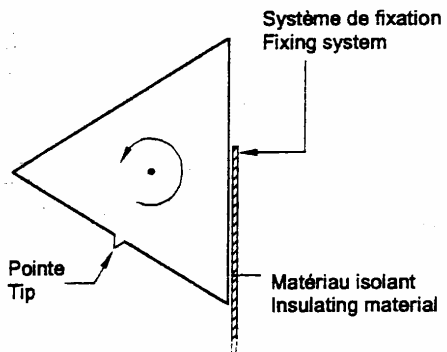

Figure 5Yb - Initial position of mandrel

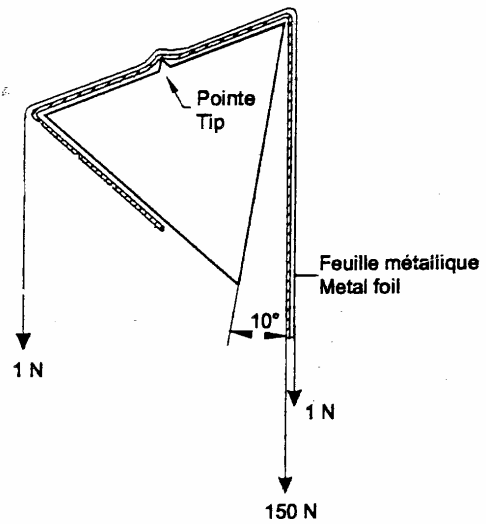

Figure 5Yc - Final position of mandrel

Explanatory notes:

The above procedure was agreed upon in the meetings of IECTC74-WG6. CTL was asked to produce this decision sheet to publish the test procedure.
See also similar sheet for IEC 60065.